

# Isla Sygma

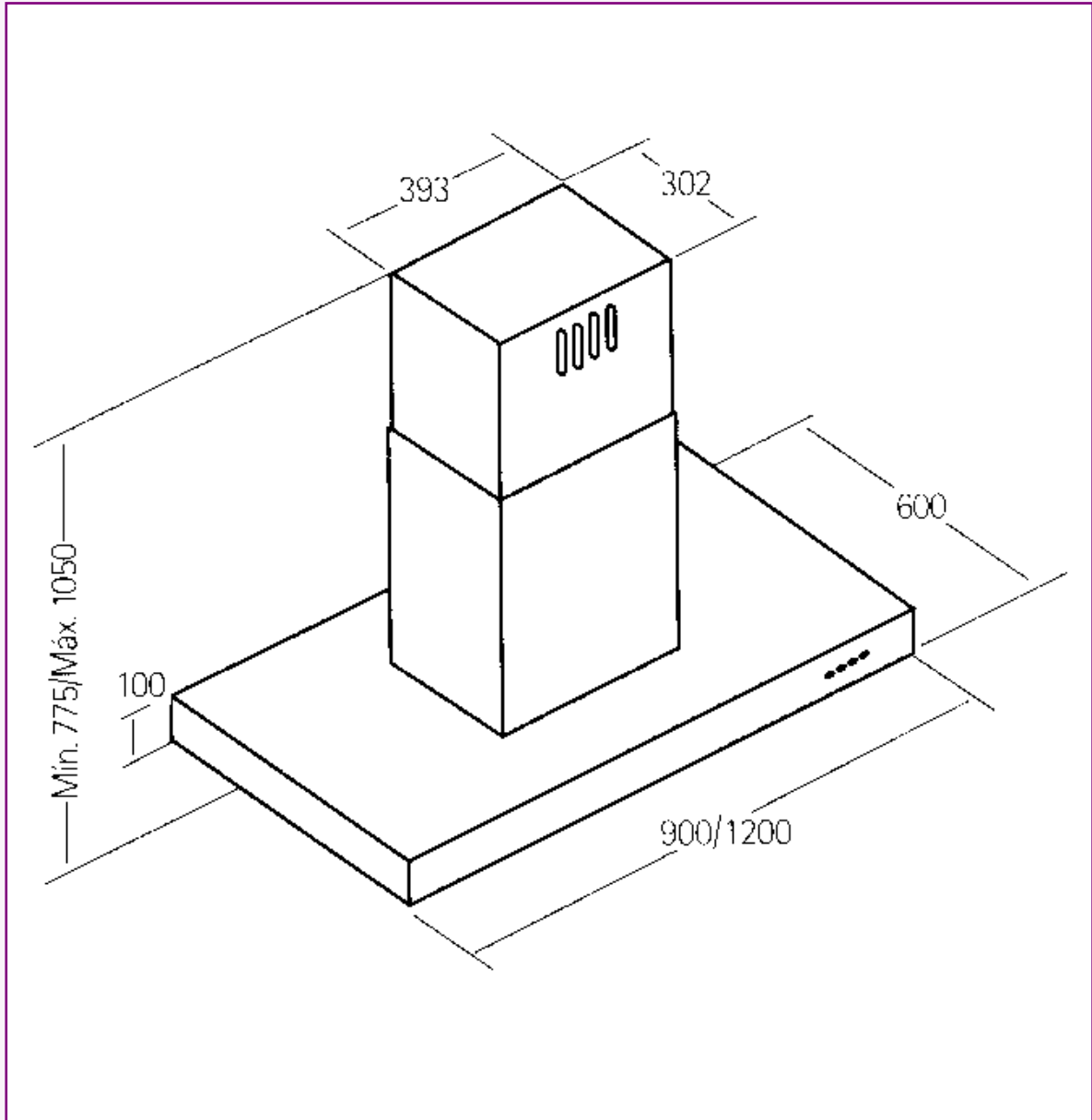

- Slimline island canopy
- Extract only
- 3 speed soft touch electronic control with 15 minute timer
  - airflow 3 - 851 m<sup>3</sup>/hr
  - airflow 2 - 720 m<sup>3</sup>/hr
  - airflow 1 - 590 m<sup>3</sup>/hr
- Air pressure - 507 Pa
- 2/4 x 50w halogen lights (900/1200)
- 6/8 washable grease filters (900/1200)
- Adjustable chimney height
- Available in 90cm and 120cm width
- Powerful tangential 240w motor
- In stainless steel

# *Isla Sygma*



**Vectaire Ltd**  
Lincoln Road  
Cressex Business Park  
High Wycombe  
Bucks, HP12 3RH  
Tel: +44(0)1494 522333  
Fax: +44(0)1494 522337  
Email: [sales@vectaire.co.uk](mailto:sales@vectaire.co.uk)

